

# BLYSG34xS Series - Brushless DC Spur Gear Motors



## FEATURES

- **NEMA Size 34 BLDC Motor with Spur Gearboxes**
- **Compact Size and Power Density**
- **Cost-Effective Solution**
- **Lifetime of over 2,000 hours**
- **Available in Single and Double Options Shaft**
- **Can be Customized for**
  - Maximum Speed/Winding Current
  - Shaft Options and Modifications
  - Cables and Connectors
- **CE Certified, and RoHS Compliant**



## DESCRIPTION

The BLYSG34xS Series Brushless DC Spur Gearmotors come in a compact package with high power density. These motors are cost-effective solutions to many velocity control applications. They come in three stack lengths to provide just the right torque for a specific application. A number of windings are available off-the-shelf and the motors can be customized to fit specific machine requirements. The motor comes in a standard 11-lead configuration and can be wired for either delta or star configurations. We can also customize the winding to perfectly match your voltage, current, and maximum operating speed. Special shaft modifications, gear ratios, cables and connectors are also available upon request.

## SPECIFICATIONS

Model #	FRAME Size	Rated Voltage (V)	Rated Speed (RPM)	Rated Power (W)	Peak Torque (oz-in)	Peak Current (A)	Torque Constant (oz-in/A)	Back EMF voltage (V/kRPM)	Reflected Inertia (oz-in-se-c <sup>2</sup> )	Weight* (lbs)	L1 (in)	L2** (in)	Total Length (in)
BLYSG341S-48V-3200-R5	NEMA 34	48	640.0	110	750	57	13.2	52.5	0.142	5.78	1.65	2.28	4.05
BLYSG342S-24V-3000-R75	NEMA 34	24	40.0	220	22500	30	750.0	450.0	63.56	6.70	2.95	2.80	5.75
BLYSG343S-48V-3200-R3	NEMA 34	48	1066.7	440	1800	11	163.6	40.5	0.204	8.22	1.65	3.86	5.63
BLYSG343S-48V-3200-R5	NEMA 34	48	640.0	440	3000	11	272.7	67.5	0.568	8.22	1.65	3.86	5.63
BLYSG344S-48V-3200-R3	NEMA 34	48		660						10.25			

*Custom leadwires, cables, connectors, and windings are available upon request. Available gear ratios are: R3, R7.5, R15, R25, R30, R50, R100, R120, R150.*

*\*Weights will vary based on gear ratio selected.*

*\*\*Overall length of gearmotors will vary based on gear ratio selected.*

L010377

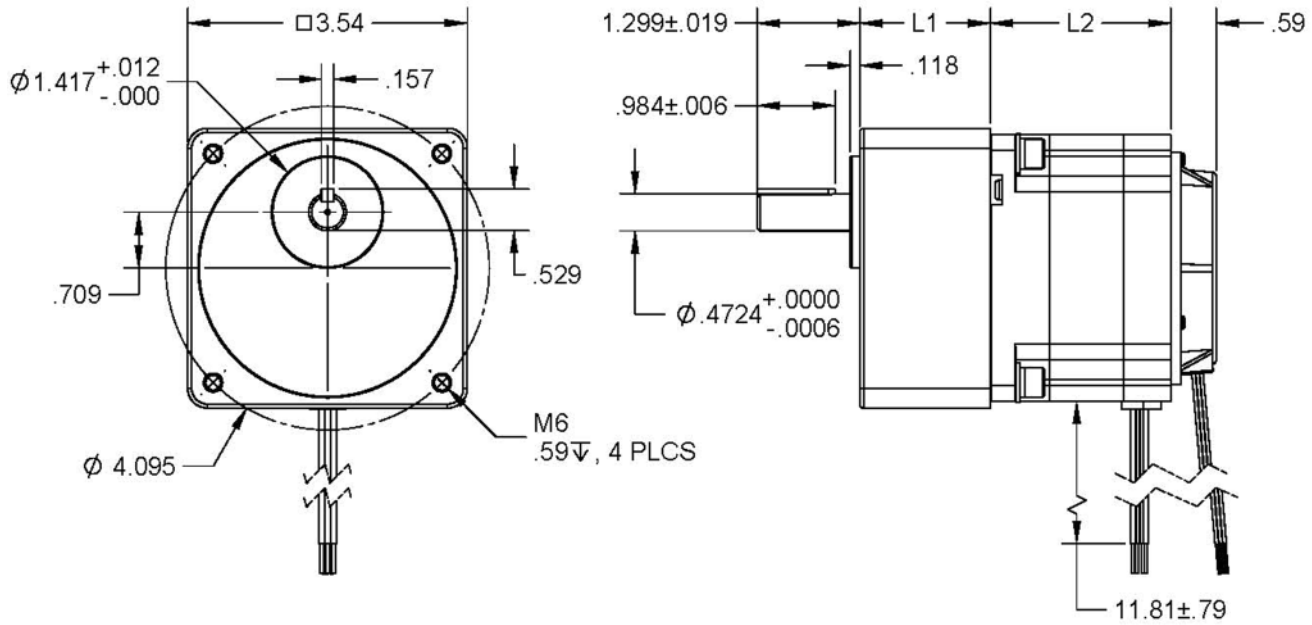

Description	Motor Wire Color	Cable Adder Color
Hall Supply	Red	Red/White
Hall A	Blue	Orange/White
Hall B	Green	Orange
Hall C	White	Yellow/White
Hall Ground	Black	Black/White
Phase A	Yellow, Yel/Wht	Yellow
Phase B	Red, Red/Wht	Red
Phase C	Black, Blk/Wht	Black

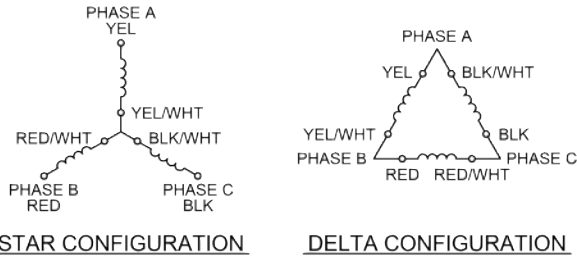

STAR CONFIGURATION

DELTA CONFIGURATION

- NOTE:  
 1. STAR CONFIGURATION IS DEFAULT.  
 2. FOR DELTA CONFIGURATION:

REMOVE PLASTIC CAP.  
 REMOVE 3 SCREWS HOLDING PCB.  
 ROTATE HALL PCB TO LINE UP WITH RED MARKER, REPLACE SCREWS.  
 REPLACE PLASTIC CAP.

Hall effect angle:	120° electrical angle	Number of poles:	8
Insulation Class	Class B	Number of phase:	3
Dielectric strength	500VDC for one minute	Temperature Rise:	70° C
Insulation resistance:	100MOhms Min, 500VDC	Life Expectancy:	Over 2000 hours