

# MDC151-050301 - Brushless DC Controller



## FEATURES

- Maximum Current Limit Setting from 10.0-30.0 Amps
- Internal or External Potentiometer Speed Control
- 0V to 5V External Voltage Speed Control
- 2-Quadrant Operation
- Hall Sensor Feedback
- Constant Velocity Mode
- Short Circuit Protection
- Requires 20-50 VDC
- Run/Stop, Freewheel and Direction Inputs
- TTL-CMOS Compatible Inputs
- Dual Mounting Option



## DIMENSIONS

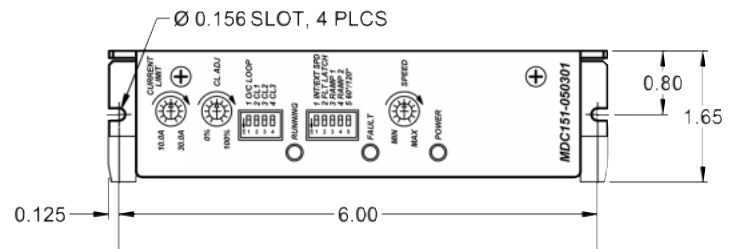
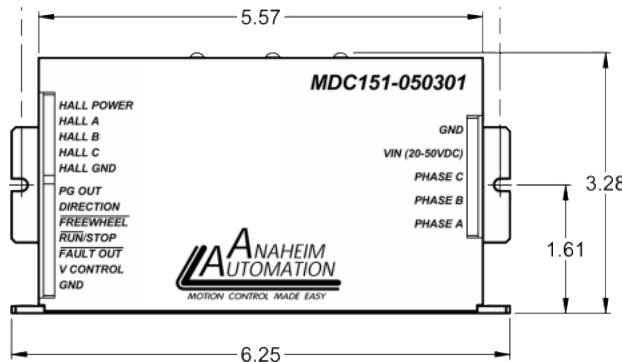

## DESCRIPTION

The MDC151-050301 driver is designed to drive DC brushless motors at currents of up to 30A (peak) and 50V. Using hall sensor feedback, a constant velocity mode can be selected. The driver is protected against over current (cycle-by-cycle or latched), hall sensor error and under voltage. When an error occurs, a fault light and a fault output are turned on to notify the user. Included on the driver is an internal potentiometer to control the maximum phase current allowed into the motor and an internal potentiometer to control the speed of the motor. An external voltage (0-5VDC) can be used to control the speed as well. The direction of the motor can be preset by the direction control input.

Other inputs to the drive include a run/stop and a motor freewheel input. When using the run/stop input, there are three ramp up/down profiles from standstill to select from. The run/stop input overrides all other inputs into the driver.

### Ideal Applications:

Automated machinery or processes that involve food, cosmetic, or medical packaging, labeling, or tamper-evident requirements, electronic assembly, robotics, factory automation, special filming and projection effects, medical diagnostics, inspection and security devices, conveyor and material handling systems, pump flow control, XY and rotary tables, equipment upgrades or wherever speed control is required.

L010409

## Torque Speed Curves

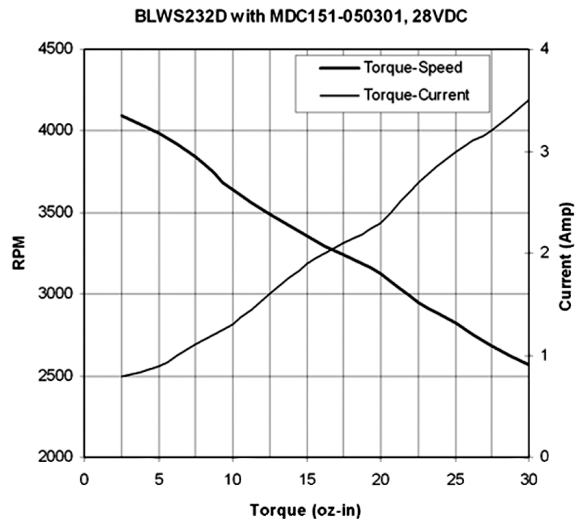
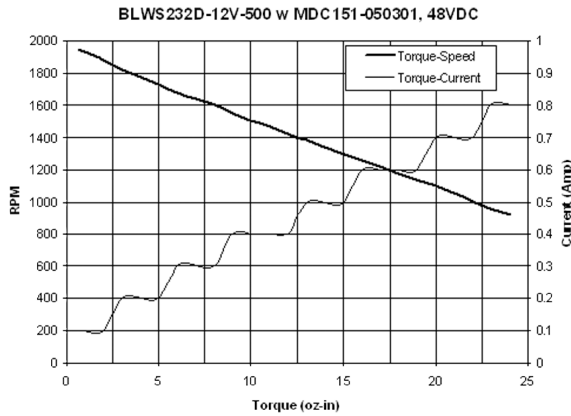

## Specifications

**Control Inputs:** (TB3, Pins 2-4) TTL-CMOS compatible  
Logic "0" = 0-0.8VDC  
Logic "1" = Open

**Direction Control:** (TB3, Pin 2) Logic "1" (open) - Clockwise  
Logic "0" - Counterclockwise

**Freewheel:** (TB3, Pin 3) Logic "1" (open) - Motor is Enabled  
Logic "0" - Motor is de-energized and will coast

**Run/Stop:** (TB3, Pin 4) Logic "1" (open) - Motor will not run and if running will decelerate according to ramp dip switch setting  
Logic "0" - Motor will run and will accelerate according to ramp dip switch

**V Control:** (TB3, Pin 4) To control the speed of the motor with an external DC voltage, INT/EXT SPD switch (SW1-POS1) must be switched to the ON position.  
(0VDC (min) - 5 VDC (max))

**Control Outputs:** (TB3, Pins 1 and 5) TTL-CMOS Compatible  
These outputs are able to sink 50mA.

**Speed Output:** (TB3, Pin 1) A 5V signal pulse out is available at a rate of 4 pulses for 1 revolution of an 8-pole motor, 3 pulses for 1 revolution of a 6-pole motor, and 2 pulses for 1 revolution of a 4-pole motor.  
8-pole motor RPM = 15 \* PG OUT (in Hz)  
6-pole motor RPM = 20 \* PG OUT (in Hz)  
4-pole motor RPM = 30 \* PG OUT (in Hz)

**Fault Output:** (TB3, Pin 5) Logic "1" (5V out) - Status good, normal operation.  
Logic "0" - One of the three fault conditions listed in the 'Fault Protect' section has occurred. When a fault is detected, the Fault Output (Pin 5) goes low.

## Hookup:

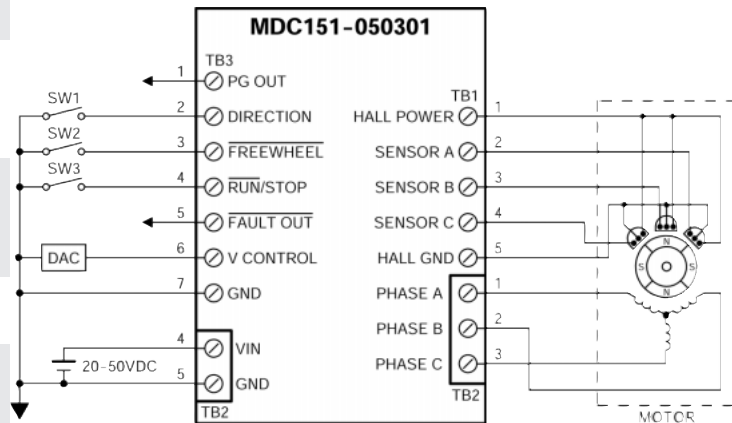

## Power Supply Ordering Information

Model #	Description
PSAM24V2.7A	DC Power Supply 24VDC at 2.7 Amps
PSA40V4A	DC Power Supply 40VDC at 4.0 Amps
PSA40V8A	DC Power Supply 40VDC at 8 Amps